

JBC

www.jbctools.com

INSTRUCTION MANUAL



ALE250

Auto Feed Iron

This manual corresponds to the following reference:

- ALE250-A

Packing List

The following items are included:



Auto Feed Iron 1 unit

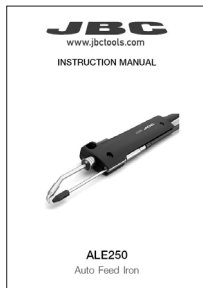

Manual 1 unit
Ref. 0028271

Features and Connections



Compatible Cartridges

ALE250 Auto Feed Iron works with C250 cartridges. Find the model that best suits your soldering needs in www.jbctools.com

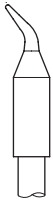

Conical Bent



Chisel



Chisel Bent



Bevel

* Control Unit, Cartridge and Guide Set not included

Tool Assembly

Connect the tool to the control unit following this steps:

Insert and push the guide nozzle until the end (1) and tighten the screw (2). Then connect the tool connector (3).

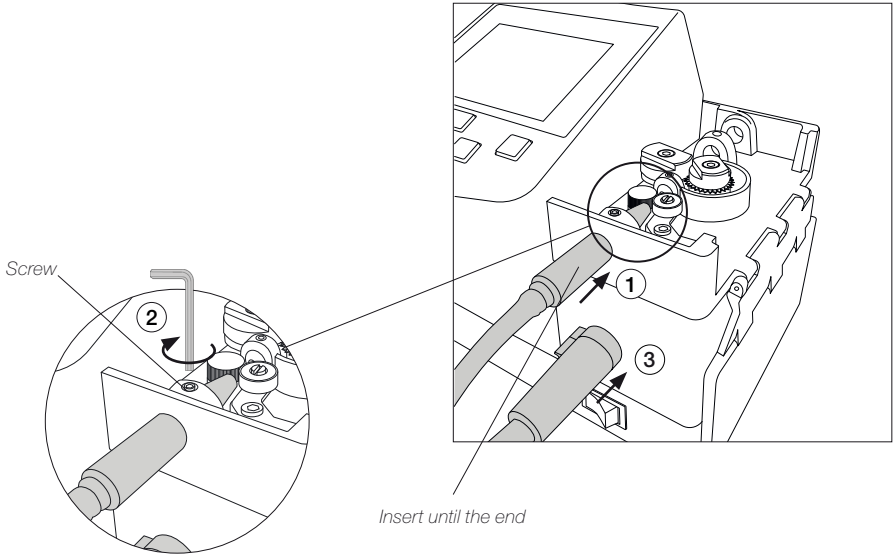

Solder Wire Loading

Pass the solder wire through the wire guidance and introduce the solder wire into the inlet nozzle (1) until it reaches the wheels (2).

Make sure the wire passes through the Intermediate Nozzle (5) and enters into the Guide Tube (6).

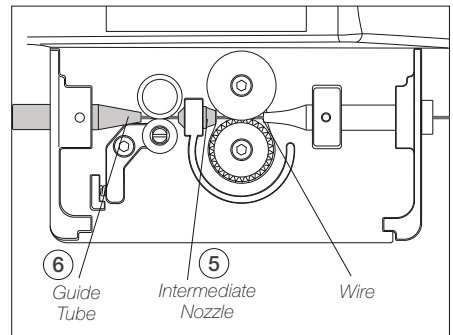
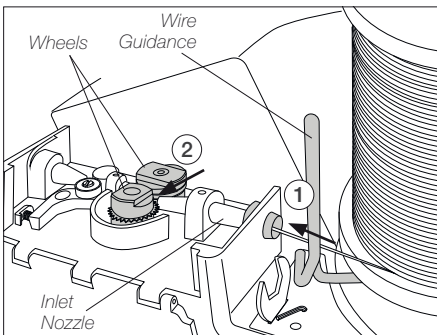

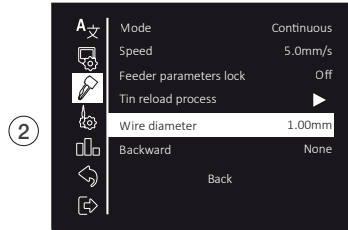
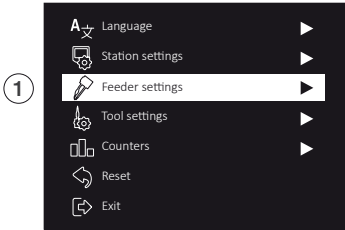

Main Menu Screen

Access to Main Menu by , select “Feeder Settings” (1) and then “Wire Diameter” (2) to adjust the value to the current solder wire diameter.



Tin Reloaded Process Screen

Select “Tin Reloaded Process” (1) and then use  to feed the solder wire and advance until it comes out through the outlet nozzle. Keep  pressed and after a while the wire will advance faster.

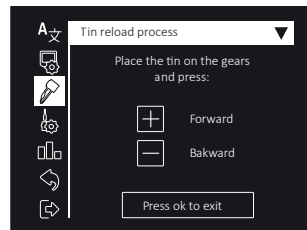
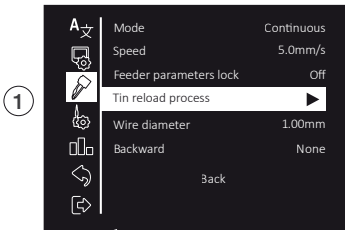

Solder Wire Feeding

Forward the solder wire by pushing the dragging button (4) until the wire comes out of the tip (5).

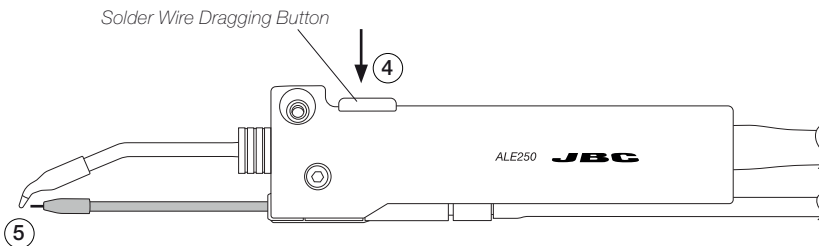

To feed the solder wire, alternatively the pedal P405 can be used. The pedal should be plugged in at the rear of the feeder control unit into the pedal connector.



Changing Cartridges

⚠ For a safe cartridge change, unplug the tool or turn the station off before following these guidelines:

Loosen the cartridge screw (1) to release the cartridge (2). Place a new one into the auto-feed iron.

Important: It is essential to insert the cartridge till the end for a good connection. Use the mark as reference (3).

Align the tip of the cartridge with the guide nozzle (4) and tighten the cartridge screw (1)

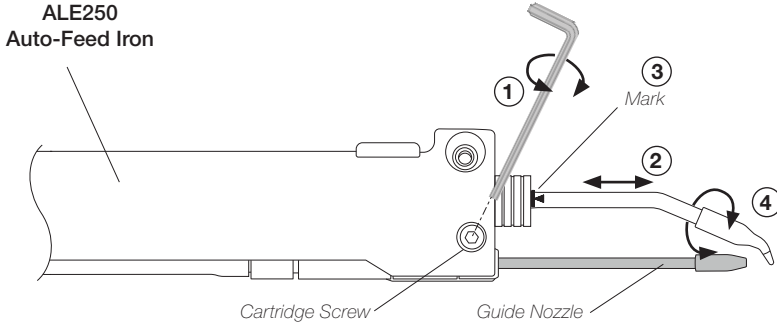

Replacing Guide Sets

Once the tool is disconnected from the control unit and has cooled down, follow these instructions:

Disassemble the outlet nozzle (1) from the guide set.

Loosen the guide set screw (2), take out the guide set (3) and insert the desired one.

Put the outlet nozzle (1) back on again. Leave a gap of 8 to 10 mm between the cartridge tip and the outlet nozzle (4).

Once the guide nozzle length is adjusted tighten the guide set screw (2).

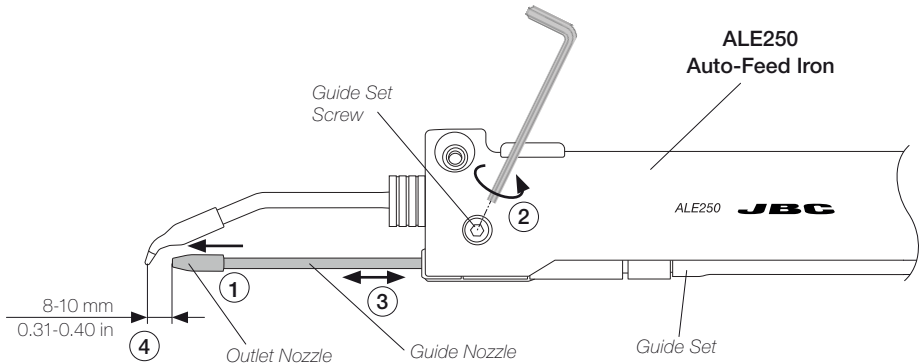

Accessories

GALE Guide Kits



References for GALE Guide Kits without Solder Wire Perforation

Solder Wire Ø range of use	Guide Kit Ref.	Guide Set Ref.	Outlet Nozzle Ref.	Nozzle Ref.	Traction wheel Ref.	Support wheel Ref.	Inlet nozzle Ref.	Intern. Nozzle Ref.	Counter Wheel Ref.	Screw Ref.	Headless Screw Ref.
0.38 - 0.40 mm 0.015 - 0.016 in	GALE04D-A	0028358	0025268	0021158	0019479	0020345	0019520	0024954	26693	0026695 (x2)	0026696 (x3)
0.46 - 0.56 mm 0.018 - 0.022 in	GALE05D-A										
0.60 - 0.64 mm 0.023 - 0.025 in	GALE06D-A	0025289	0025291								
0.70 - 0.78 mm 0.028 - 0.031 in	GALE07D-A					0025270	0024955				
0.80 - 0.82 mm 0.032 - 0.033 in	GALE08D-A	0028360	0024956								
0.90 - 1.10 mm 0.036 - 0.044 in	GALE10D-A					0028361	0024957				
1.14 - 1.27 mm 0.045 - 0.051 in	GALE12D-A	0025272	0024958								
1.50 - 1.57 mm 0.060 - 0.063 in	GALE15D-A					0025274	0024959				
1.60 - 1.63 mm 0.063 - 0.065 in	GALE16D-A	0028363	0024960								
1.80 mm 0.073 in	GALE18D-A					0021559					



References for GALE Guide Kits with Solder Wire Perforation

Solder Wire Ø range of use	Guide Kit Ref.	Guide Set Ref.	Outlet nozzle Ref.	Nozzle Ref.	Guide Wheel Ref.	Blade Ref.	Blade Clamp Ref.	Inlet nozzle Ref.	Intern. Nozzle Ref.	Counter Wheel Ref.	Screw Ref.	Headless Screw Ref.
0.8 mm 0.032 in	GALE08V-A	0028358	0025270	0021158	0021696	0021555	0018638	0018632	0024955	0026693	0026695 (x2)	0026696 (x3)
1.0 mm 0.040 in	GALE10V-A	0028359			0021699			0019170	0024956			
1.2 mm 0.047 in	GALE12V-A	0028360	0025272		0019171					0024957		
1.5 mm 0.059 in	GALE15V-A	0028361	0025274					0026694	0024958			
1.6 mm 0.063 in	GALE16V-A	0028363	0025276		0024233					0024959		

Accessories

Fume Extractor

Ref. F4468 - 2 m (78.74 ft) length.

The fume extractor for AL250 is an easy & safe solution to suck the fume generated at the solder joint.

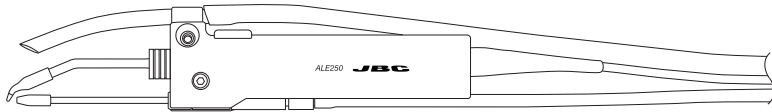

Maintenance

- Before carrying out maintenance, always unplug the stand and the tool.
- Check periodically that the metal parts of the tool and the stand are clean to ensure detection of the tool when it is in the stand. Use a damp cloth or alcohol.
- Periodically check all cables and tubes connections.
- Replace any defective or damaged pieces. Use original JBC spare parts only. Repairs should only be performed by a JBC authorized technical service.

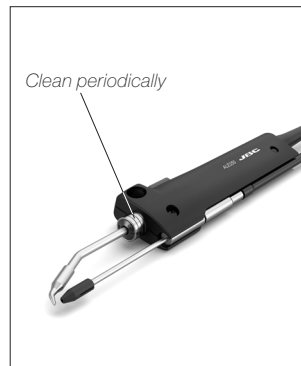
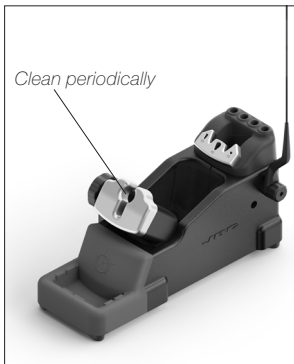

Safety

It is imperative to follow safety guidelines to prevent electric shock, injury, fire or explosion.

- Do not use the tool for any purpose other than soldering or rework.
- The power cord must be plugged into approved bases. Be sure that it is properly grounded before use. When unplugging it, hold the plug, not the wire.
- The tool should be placed in the stand when not in use in order to activate the sleep mode. The soldering tip, the metal part of the tool and the stand may still be hot even when the station is turned off. Handle with care, including when adjusting the stand position.
- Avoid the contact of flux with skin or eyes to prevent irritation.
- Be careful with the fumes produced when soldering.
- Keep your workplace clean and tidy. Wear appropriate protection glasses and gloves when working to avoid personal harm.
- Utmost care must be taken with liquid tin waste which can cause burns.
- This appliance can be used by children over the age of eight and also persons with reduced physical, sensory or mental capabilities or lack of experience provided that they have been given adequate supervision or instruction concerning use of the appliance and understand the hazards involved. Children must not play with the appliance.
- Maintenance must not be carried out by children unless supervised.

Specifications

ALE

Auto Feed Iron

Ref.: **ALE250-A**

- Total Net Weight: 148 gr / 0.33 lb
- Dimensions: 35 x 21 x 182 mm / 1.42 x 0.83 x 7.16 in
- Solder Wire Diameter: Ø 1 mm / 0.039 in

- Package Dimensions / Weight: 300 x 125 x 65 mm / 257 g
(L x W x H) 11.81 x 4.92 x 2.56 in / 0.57 lb

Complies with CE standards.
ESD safe

JBC

Warranty

JBC's 2 year warranty covers this equipment against all manufacturing defects, including the replacement of defective parts and labour.

Warranty does not cover product wear or misuse.

In order for the warranty to be valid, equipment must be returned, postage paid, to the dealer where it was purchased.

Get 1 extra year JBC warranty by registering here:
<https://www.jbctools.com/productregistration/>
within 30 days of purchase.



This product should not be thrown in the garbage.

In accordance with the European directive 2012/19/EU, electronic equipment at the end of its life must be collected and returned to an authorized recycling facility.



www.jbctools.com